

[DIGITAL MEDIA AUTOMATION INC](#)

12815 Stone Canyon Rd.
Poway, CA 92064
Tel: (858) 673 8505

E-mail: dma@dmaut.com
web: www.dmaut.com
Fax: (858) 673 8501

[DMA Automated Product Stacker](#)

This automated system stacks products in pre-configurable stack sizes. The system can be used to stack a continuous feed of products traveling along a conveyor line into vertical stacks, saving space and facilitating the packing of products into shipping boxes. Products accumulate on the in-feed conveyor during ejection cycles, enabling the system to handle 65 products per minute without pause. This feature enables the DMA stacker to be incorporated into almost any continuous packaging line. Adjustments can be made in minutes to accommodate products of various sizes.

[DMA Universal Product Stacker](#)

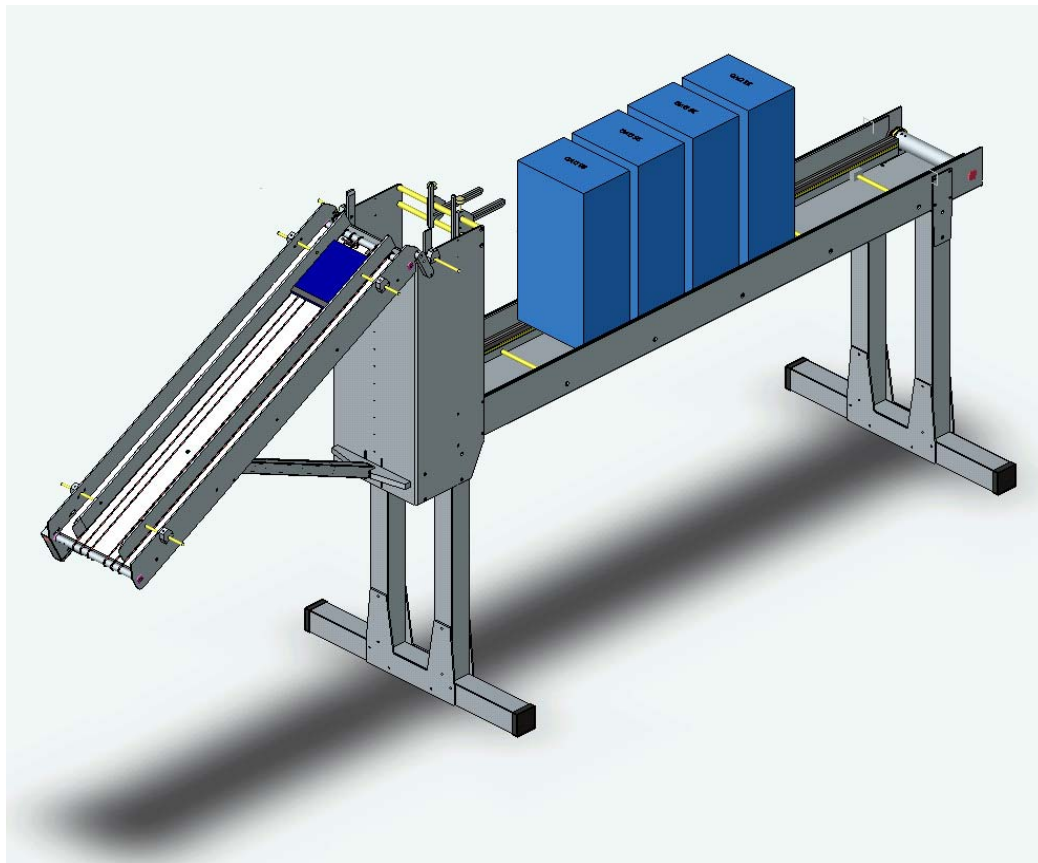

Automated Product Stacker Specifications:

- Product Sizes:

Maximum Width:	8.5 inches
Maximum Length:	6.0 inches
Maximum Height:	3.0 inches
Minimum Width:	2.0 inches
Minimum Length:	2.0 inches
Minimum Height:	.05 inches

Note: The sizes listed encompasses: CD, DVD, VHS, DAT, Audio Tape, 3.5" discs, 8 mm, DV, Betacam and more.

- Stack Height: Maximum: 18 inches
Minimum: 1 inch
- Speed: Approximately 65 parts per minute
- Physical Size: 18" W, x 60" L, x 38" H
- Stand Height: Adjustable
- Electrical Connectivity: Regular 110/220 VAC wall outlet
- Pneumatic Connectivity: Not required
- Interface: Full interface to other equipment
- Product entry: In-feed conveyor
- Optional: Extended out-feed conveyor
- Optional: Bar-Code reader to verify product ID

PRICE: \$10,000..... FOB POWAY CA